

Hale School

Physics 3B

2010



# Electrodynamics

## Year 12 Study Notes

Name:

Teacher:

Set:

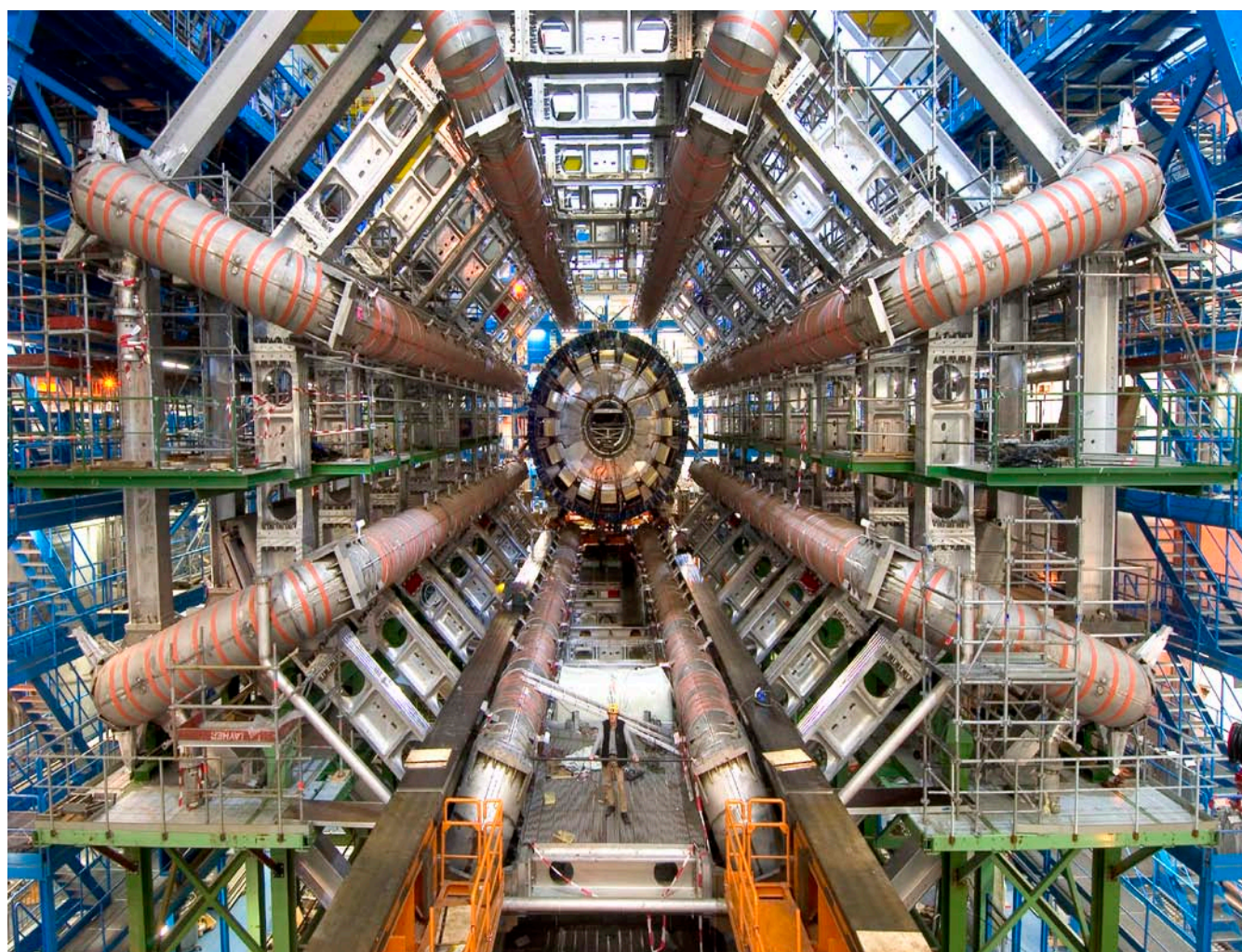

## Table of Contents

Electric Fields (Review).....	3
Lines of Force.....	3
Electric Potential.....	4
Electric Field Strength.....	5
Deflection of Charges in Electric Fields.....	6
Exercise Set 1: Deflection in Uniform Fields.....	8
Forces on Moving Charges in a Magnetic Field.....	11
Path Followed by Charges in Magnetic Fields.....	12
Exercise Set 2: Charged particles in Magnetic Fields.....	14
Particle Accelerators.....	15
The Electron Gun.....	16
The Mass Spectrometer.....	17
Exercise Set 3: The Mass Spectrometer.....	18
The Cyclotron.....	19
Early Synchrotrons.....	20
The Large Hadron Collider.....	21
The Australian Synchrotron.....	23

## Electric Fields ( a selected review of unit 2B)

---

The "field concept" is used to explain how a charged object can exert a force on another charged object that is separated from it in space.

An electric field is a region in space where a body experiences a force due to its electrical condition.

Every charged body, has an associated electric field. Thus when a charged body is located in an electric field, it experiences a force due to its interaction with the field.

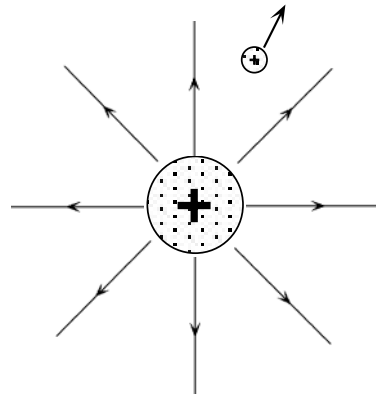

Electric Field About a Positive Charge

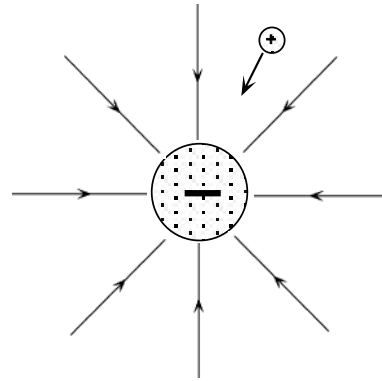

Electric Field About a Negative Charge

### Lines of Force

In the diagram the spheres may be considered as point charges.

Lines of force are used to represent the electric fields associated with the point charges.

Each line indicates the path followed by the **small positive test charge** (+q) located in the field.

About the positive charge the lines of force radiate out and away from the charge while lines of force about the negative charge act radially towards the charge.

The direction of a line of force at any point in the field is the direction of the force acting on a positive test charge at that point and opposite in direction to the force acting on a negative charge.

- Lines of force can never intersect as this would imply that the electric field at the point of intersection has two directions.
- The relative concentration of lines of force in a region is a direct indication of the field strength. The more concentrated the lines the greater the field strength.
- Lines of force run from positions of positive potential to positions of negative potential.

## Composite Fields

Electric fields interact to form composite fields.

The shape of such fields can be determined by observing the path followed by a small positive test charge placed in the field.

The shape of composite fields associated with adjacent point charges are shown here.

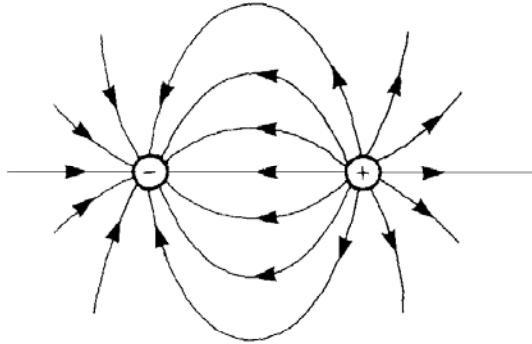

Electric field between two unlike charges

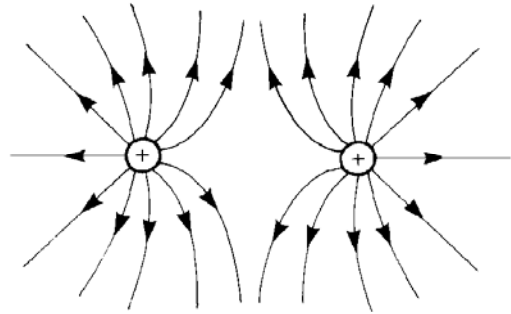

Electric field between two like charges

Sketch the composite field between a pair of charged parallel plates.

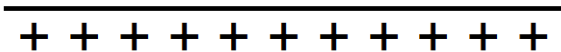

## Electric Potential

A charge at a point in an electric field has an associated potential energy  $E_p$  (cf. a mass in a gravitational field).

The electric potential at this point,  $V_p$  is defined as the potential energy per unit charge.

$$V_p = \frac{E_p}{q}$$

### Example:

Calculate the potential at point in a field if a charge of  $1.20 \mu\text{C}$  has a potential energy of  $7.20 \times 10^{-3} \text{J}$ .

$$E_p = 7.20 \times 10^{-3} \text{J}$$

$$q = 1.20 \mu\text{C}$$

$$\begin{aligned} V_p &= \frac{E_p}{q} \\ &= \frac{7.2 \times 10^{-3}}{1.2 \times 10^{-6}} \\ &= 6.00 \times 10^3 \text{ V} \end{aligned}$$

## Change In Potential Between Parallel Plates

The field lines between charged parallel plates are parallel and equally separated (uniform field).

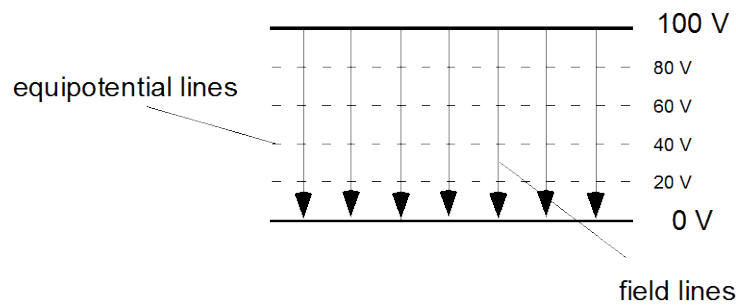

Since equipotential lines are perpendicular to the field lines, they run parallel to the plates and are also equally spaced.

The change in potential between two plates is thus directly proportional to the displacement between the two points in a direction perpendicular to the plates.

Note there is no change in potential when a charge is displaced parallel to the plates.

When the charge moves to a new point in an electric field its potential energy changes.

The potential difference between the two points is thus the change in potential energy (ie work done) per unit charge.

$$\text{Potential difference} = \frac{\Delta \text{ potential energy}}{\text{charge}} = \frac{\text{work done}}{\text{charge}}$$

$$V = \frac{W}{q}$$

## Electric Field Strength (E)

The size of an electric field may be defined in terms of the size of the force acting on a the small positive test charge placed in the field.

Electric field strength at a given point is thus defined as the force exerted per unit charge

$$\text{Electric field strength} = \frac{\text{force experienced}}{\text{charge}}$$

$$E = \frac{F}{q}$$

The SI unit for electric field strength is the newton per coulomb ( $\text{NC}^{-1}$ )

Electric field strength is a vector. The direction of the field vector is the same as the direction of the force exerted on a positive test charge.

### Example:

A point charge of 4.00 nC experiences a force of  $6.40 \times 10^{-6}$  N in an electric field. What is the field strength at that point in the field?

$$q = 4.00 \text{ nC} = 4.00 \times 10^{-9} \text{ C}$$

$$F = 6.40 \times 10^{-6} \text{ N}$$

$$\begin{aligned} E &= \frac{F}{q} \\ &= \frac{6.40 \times 10^{-6}}{4.00 \times 10^{-9}} \\ &= 1.60 \times 10^3 \text{ NC}^{-1} \end{aligned}$$

## Electric Field Between Parallel Plates

The electric field between a pair of parallel plates is found to be uniform (ie the field intensity does not vary). As a result the field lines between the plates are straight parallel lines evenly spaced. Why?

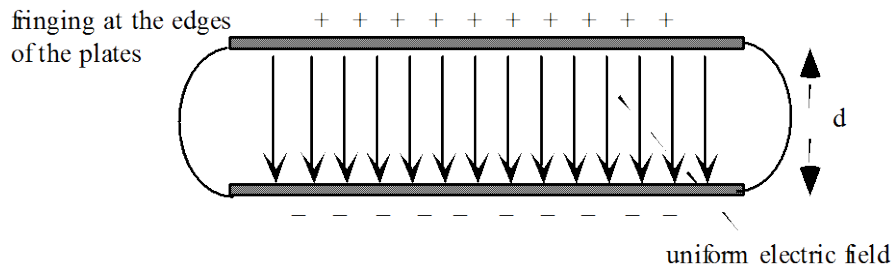

Since the field strength between the plates is uniform (constant), a constant force  $F$  is experienced by a charge at any position between the plates.

Thus if a charge  $q$  moves between the plates then the work done on the charge is  $W = Vq$

But the work done on the charge by the field is  $W = Fd$

$$\therefore Vq = Fd$$

$$\text{or } \frac{F}{q} = \frac{V}{d}$$

$$\text{but } E = \frac{F}{q} = \frac{V}{d}$$

Thus the electric field intensity between a pair of parallel plates that have a potential difference  $V$  and are separated by distance  $d$  is given by

$$E = \frac{V}{d}$$

## Deflection of Charges in an Electric Field

When a charge enters an electric field the charge experiences acceleration due to the resultant force acting on it.

### Example:

The potential difference between a pair of parallel plates is 80.0 V and they are 20.0 cm apart. Determine:

- the acceleration;
- the kinetic energy acquired by a proton as it moves between them.

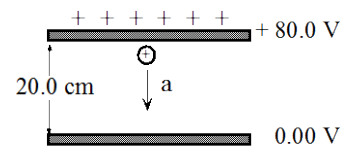

[Charge on an electron  $e = 1.6 \times 10^{-19}$  C. Mass of a proton  $m_p = 1.673 \times 10^{-27}$  kg]

$$E = \frac{F}{q} \quad \text{also } E = \frac{V}{d} \quad \therefore \frac{F}{q} = \frac{V}{d} \quad \text{but } F = ma \quad \text{thus } \frac{ma}{q} = \frac{V}{d} \quad \text{or } ma = \frac{Vq}{d}$$

$$\therefore a = \frac{Vq}{md} = \frac{80 \times 1.6 \times 10^{-19}}{1.673 \times 10^{-27} \times 0.2} = 3.83 \times 10^{10} \text{ ms}^{-2}$$

$$\text{b) } E_k = W = Vq = 80 \times 1.6 \times 10^{-19} = 1.27 \times 10^{-17} \text{ J}$$

Assume an electron is fired horizontally between a pair of charged parallel plates.

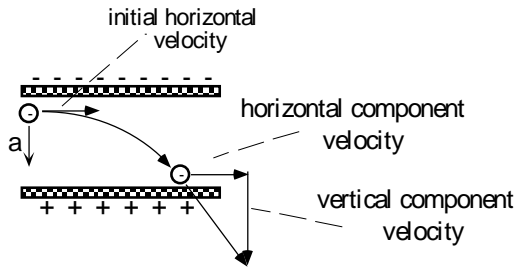

The force on the electron due to the electric field causes the electron to accelerate vertically.

Since the acceleration is perpendicular to the original direction of the electron, the acceleration has no effect on the horizontal component of the electrons velocity.

However it does produce an increasing component velocity in the vertical direction.

**Problem:**

An electron enters the field between a pair of parallel plates 25.0 cm apart with a velocity of  $1.60 \times 10^6 \text{ ms}^{-1}$ .

How far does the electron travel before striking the positive plate if the potential difference across the plates is 4.00 kV?

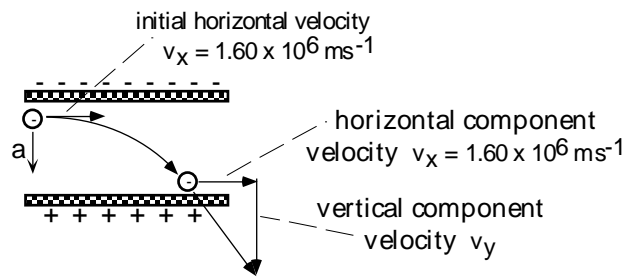

**Step 1.** The acceleration on the electron is determined.

---



---



---



---



---



---



---



---

**Step 2.** The time taken for the electron to move vertically across the plates is calculated.

The vertical displacement of the electron is given by  $s_y = \frac{1}{2}at^2$   
 Thus the time for electron to move vertically between the plates is:

---



---



---

**Step 3.** The horizontal displacement of the electron during this time is:

---

---

---

---

---

Thus the electron moves horizontally before striking the plate.

### Exercise Set 1: Deflection In Uniform Electric Fields

- Determine the force on an electron in a field of strength  $10.0 \text{ NC}^{-1}$ .
  - How does this force change if
    - the field strength is doubled
    - more electrons are added to the field?
- Calculate the force on an alpha particle ( $q = +2.00e$ ) in an electric field of strength  $3.20 \times 10^3 \text{ NC}^{-1}$ .
- The electric field strength inside a television picture tube is about  $8.00 \times 10^3 \text{ NC}^{-1}$ .  
What is the force on an electron in this field?
- A smoke precipitator has two parallel plate electrodes separated by 1.00 mm and a potential difference of  $1.00 \times 10^4 \text{ V}$ . Determine the force on a dust particle of charge  $2.00 \times 10^2 e$  placed between the electrodes. ( $e =$  charge on an electron)
- Two parallel conducting plates have a uniform electric field of strength  $160 \text{ NC}^{-1}$  between them. Calculate the acceleration of a proton placed at the positive plate.
- The electric field strength between two parallel conducting plates is  $3.20 \times 10^4 \text{ Vm}^{-1}$ . An electron initially at rest accelerates from the negative plate to the positive plate. Calculate:
  - the force on the electron at the negative plate
  - the force on the electron midway between the plates
  - the acceleration of the electron
  - the final velocity of the electron as it strikes the +ve plate, which is 5.00 cm from the -ve plate
  - the gain in kinetic energy of the electron in moving from the -ve plate to the +ve plate.
- Two parallel plate electrodes are separated by 20.0 cm and have a potential difference of  $3.20 \times 10^4 \text{ V}$ . An electron with energy  $1.00 \times 10^{-16} \text{ J}$  accelerates from the negative electrode to the positive electrode. Determine:
  - the energy of the electron as it strikes the positive electrode
  - the electric field strength between the electrodes
  - the force on the electron whilst between the electrodes
  - the acceleration of the electron.



8. A small charged oil drop is held stationary between two parallel plates between which a uniform electric field of strength  $1.00 \times 10^4 \text{ Vm}^{-1}$  exists. The mass of the oil drop is  $1.0 \times 10^{-12} \text{ kg}$ . Determine: a) the charge of the drop  
b) how many excess electrons are on the drop.

9. An electron (with mass  $9.11 \times 10^{-31} \text{ kg}$ ) is projected horizontally at a speed of  $1.00 \times 10^7 \text{ ms}^{-1}$  between two parallel plates 5.00 cm long. The electric field strength between the plates is  $1.00 \times 10^4 \text{ Vm}^{-1}$ . Calculate:

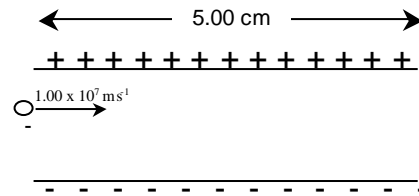

- a) the vertical force on the electron  
b) the vertical acceleration of the electron  
c) the time taken for the electron to traverse the field  
d) the vertical displacement of the electron  
e) the vertical velocity acquired by the electron.
10. An alpha particle travelling at  $1.00 \times 10^6 \text{ ms}^{-1}$  enters a uniform electric field of strength  $1.60 \times 10^5 \text{ Vm}^{-1}$  at right angles. The alpha particle has a charge twice that of a proton and it is found to take  $1.00 \times 10^{-7} \text{ s}$  to cross the field. Given the mass of the alpha particle is  $6.64 \times 10^{-27} \text{ kg}$ , determine:  
a) the length of the plates that produce the field  
b) the acceleration of the alpha particle  
c) the velocity of the alpha particle as it leaves the field.
11. What must be the magnitude of an electric field strength, so that an electron placed in the field experiences an electrical force equal to its weight?
12. An electron moving with a speed of 10.0% that of light is shot parallel to an electric field of strength  $1.00 \times 10^4 \text{ NC}^{-1}$  so as to retard its motion. Determine:  
a) how far the electron will travel before momentarily stopping  
b) how long it will take to come to rest  
c) the fraction of its initial kinetic energy the electron loses if the electric field ends after 1.00 cm.
13. An electron is shot horizontally at  $1.00 \times 10^6 \text{ ms}^{-1}$  midway between two horizontal conducting plates placed 6.00 cm apart. A uniform electric field of strength  $1.00 \times 10^3 \text{ NC}^{-1}$  exists between the plates. Determine how far the electron travels before it strikes the positive plate.
14. A proton with a speed of  $2.00 \times 10^6 \text{ ms}^{-1}$  is projected horizontally between two parallel plates separated by 5.00 cm. The upper plate is at a potential of  $1.00 \times 10^3 \text{ V}$  and the lower plate is earthed. The plates are 10.0 cm long and a screen to detect protons is placed a further 10.0 cm from the end of the plates. Calculate:  
a) the electric field strength between the plates  
b) the vertical displacement of the electron at the end of the plates  
c) how far from the centre of the screen the proton is detected.
15. A beam of electrons is fired toward the screen in a television set. Given that the accelerating potential is about 3000 V, how far does the beam fall due to the influence of gravity?

## Answers

1. a)  $1.6 \times 10^{-18} \text{ N}$  b) i) doubles ii) no change
2.  $1.02 \times 10^{-15} \text{ N}$
3.  $1.28 \times 10^{-15} \text{ N}$
4.  $3.2 \times 10^{-10} \text{ N}$
5.  $1.53 \times 10^{10} \text{ ms}^{-2}$  towards plate of lower potential
6. a)  $5.12 \times 10^{-15} \text{ N}$  towards the positive plate  
(Hint: since the field between two parallel plates is uniform then the force is constant.)  
b)  $5.12 \times 10^{-15} \text{ N}$  towards the positive plate  
c)  $5.6 \times 10^{15} \text{ ms}^{-2}$  towards the positive plate  
d)  $2.37 \times 10^7 \text{ ms}^{-1}$  towards the positive plate  
e)  $2.56 \times 10^{-16} \text{ J}$
7. a)  $5.22 \times 10^{-15} \text{ J}$   
b)  $1.6 \times 10^5 \text{ NC}^{-1}$  towards the positive plate  
c)  $2.6 \times 10^{-14} \text{ N}$  towards the positive plate  
d)  $2.8 \times 10^{16} \text{ ms}^{-2}$  towards the positive plate
8. a)  $9.8 \times 10^{-16} \text{ C}$   
(Hint: the gravitational force is equal in magnitude to the electric force.)  
b) 6125 (Hint: there must be an integral number of electrons.)
9. a)  $1.6 \times 10^{-15} \text{ N}$  towards the plate of higher potential  
b)  $1.76 \times 10^{15} \text{ ms}^{-2}$  towards the plate of higher potential  
c)  $5 \times 10^{-9} \text{ s}$   
(Hint: the electron takes the same time to travel 5 cm across the field as without the field.)  
d) 2.2 cm towards the plate of higher potential  
(Hint: consider components perpendicular to the field only.)  
e)  $8.8 \times 10^6 \text{ ms}^{-1}$  towards the plate of higher potential
10. a) 0.1 m  
b)  $7.71 \times 10^{12} \text{ ms}^{-2}$  towards the negative plate  
c)  $1.26 \times 10^6 \text{ ms}^{-1}$  at an angle of  $37.6^\circ$  from its original path  
(Hint: find the vector sum of the perpendicular and parallel components.)
11.  $5.6 \times 10^{-11} \text{ NC}^{-1}$
12. a) 0.26 m  
b)  $1.7 \times 10^{-8} \text{ m}$   
c) 4.0 %
13. 1.85 cm along the plate
14. a)  $2 \times 10^4 \text{ V.m}^{-1}$  towards the lower plate  
b)  $2.4 \times 10^{-3}$  towards the lower plate (Hint: consider parallel components only.)  
c)  $7.2 \times 10^{-3}$  towards the lower plate  
(Hint: the proton travels in a straight line after passing between the plates.  
Find the direction of travel.)

## Forces on Moving Charges in a Magnetic Field

The force exerted by a magnetic field on a current carrying conductor is the resultant of the forces exerted on each of the moving charges comprising the current.

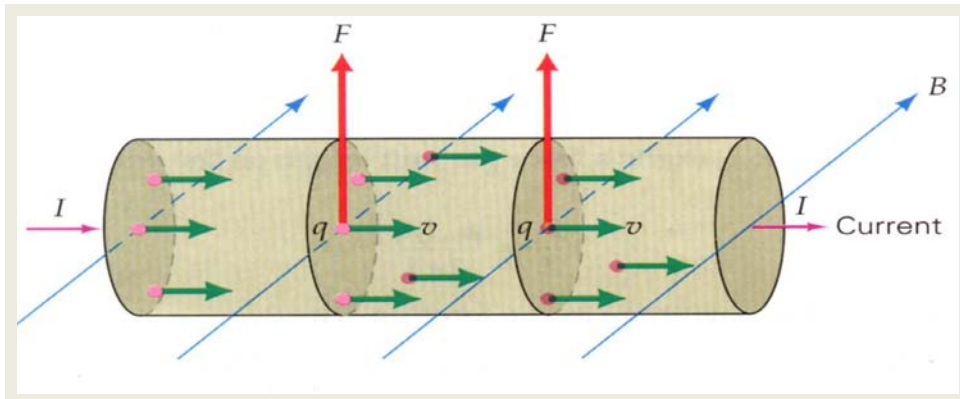

When the charges are moving, the magnetic field exerts a force on each which is transferred to the conductor in which the charges (electrons) are confined.

When electron beams (cathode rays) or other beams of charged particles pass through a magnetic field, magnetic forces will be exerted on each charged particle.

Every moving charge has its own magnetic field that interacts with the external magnetic field and thereby experiences a force.

Since the moving charged particles comprising a beam are not confined to a wire, the force will change their motion and deflect the beam from its original path.

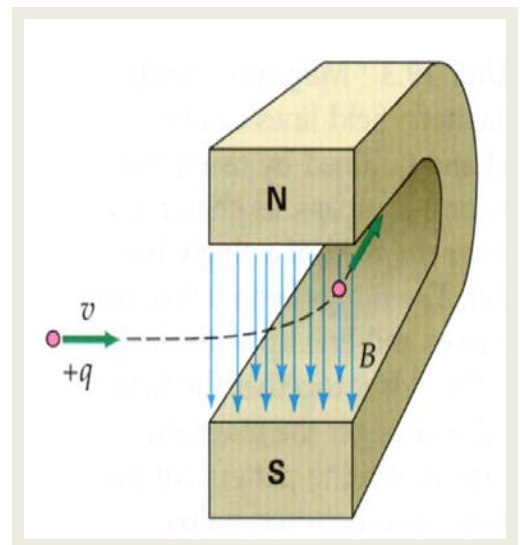

When a high voltage is applied across the metal electrodes of a Vacuum Tube, a stream of electrons (cathode ray) will move across the tube.

Applying a magnetic field to the tube will result in the deflection of the beam of electrons.

**How would the magnetic field be aligned in order to deflect a cathode ray as shown?**

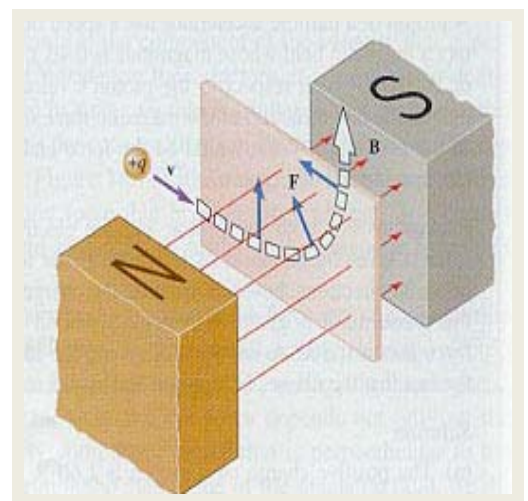
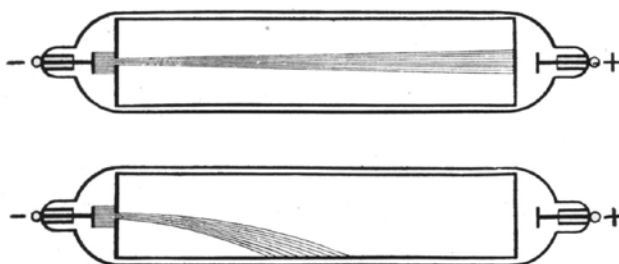

Consider a positive charge  $q$  moving with velocity  $\vec{v}$ , cutting a field of strength  $\vec{B}$ .

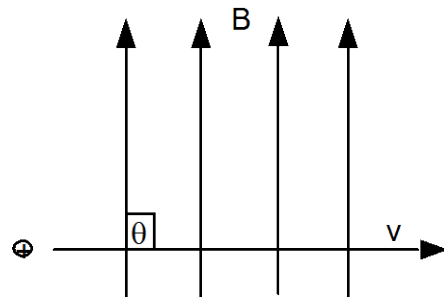
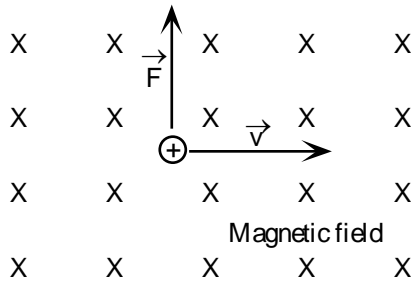

If the charge cuts the field at  $90^\circ$  then  $F = B I l$  and  $I = \frac{q}{t}$

$$\geq F = \frac{B I l}{t} \quad \text{but} \quad \frac{l}{t} = v$$

$$\geq \boxed{F = B v q}$$

$F$  = Force (N)  
 $B$  = Magnetic field strength (T)  
 $v$  = velocity ( $\text{ms}^{-1}$ )  
 $q$  = charge (C)

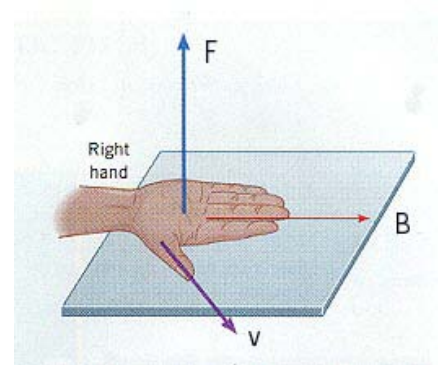

The direction of the force on a positive charge may be found using the **Right Hand Palm Rule**.

Note, for a **negative charge**, the direction of the force is determined using the left hand or is taken as opposite in direction to the force acting on a positive charge.

For a charge cutting the field at an angle  $\theta$  the relationship becomes:

$$\boxed{F = B v q \sin \theta}$$

In the diagram to the right, the velocity vector can be resolved into components parallel and perpendicular to the field.

The velocity component parallel to the field results in no force so the vertical velocity will remain the same.

The component perpendicular to the field results in circular motion around the field lines.

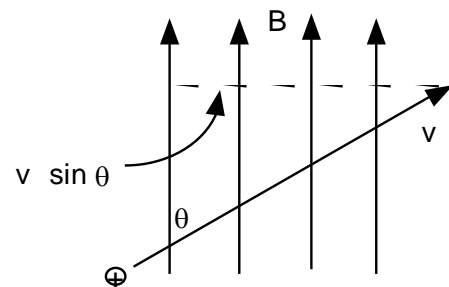

When you combine these two motions the result is a spiral or helical trajectory around the field lines.

### Path Followed by a Charge in a Magnetic Field

The force acting on a charge moving through a magnetic field is constant and acts in a direction which is mutually perpendicular to the velocity vector  $\vec{v}$  and the field strength vector  $\vec{B}$ .

As a result the charge will follow a circular path in a field of constant strength.

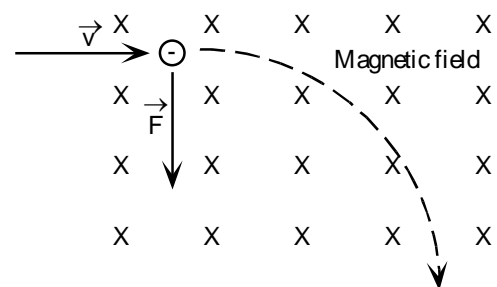

**NB:** The charge in the diagram opposite is negative, i.e. an electron.

The force acting on a charged particle moving with constant velocity at right angles to a uniform magnetic field is always perpendicular to its velocity.

Therefore, the force does not change the magnitude of the particle's velocity.

Since the charged particle accelerates at a constant rate, at right angles to its velocity, the force effects a circular path.

The force due to the magnetic field on the moving charged particle provides a centripetal force that compels it to move in a circle at a constant speed.

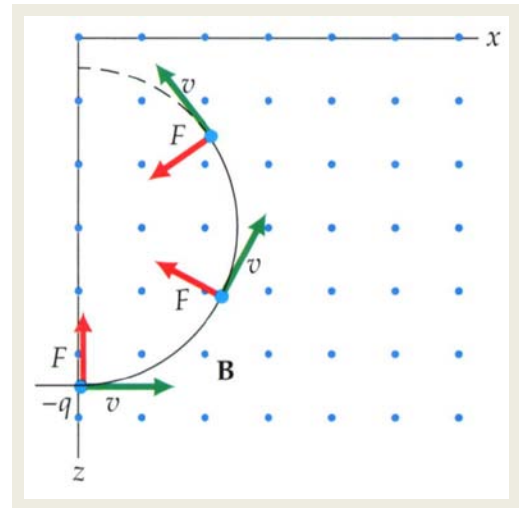

The radius of curvature of the charged particle moving in a uniform magnetic field we equate:

$$F = B \cdot q \cdot v \quad \text{and} \quad F = \frac{m \cdot v^2}{r}$$

$$\text{So: } B \cdot q \cdot v = \frac{m \cdot v^2}{r}$$

$$\text{and } \boxed{r = \frac{m \cdot v}{B \cdot q}}$$

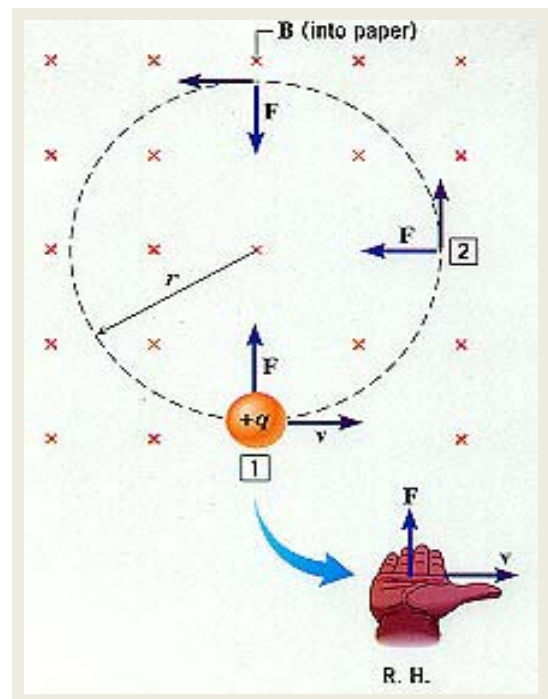

### TYPE EXAMPLE

A helium nucleus moving at  $2.50 \times 10^6 \text{ ms}^{-1}$  enters a magnetic field of strength  $5.00 \text{ mT}$  at right angles to it. Determine the radius of the curve it describes. [ $m(\alpha) = 6.68 \times 10^{-27} \text{ kg}$ ]

**Solution:**

Using  $F = B v q$

This is a centripetal force i.e.  $F = \frac{mv^2}{r}$  So:  $Bvq = \frac{mv^2}{r}$

$$r = \frac{mv^2}{Bvq} = \frac{mv}{Bq} = \frac{6.68 \times 10^{-27} \times 2.50 \times 10^6}{5.00 \times 10^{-3} \times 2(1.60 \times 10^{-19})}$$

$$\geq r = \underline{\underline{10.4 \text{ m}}}$$

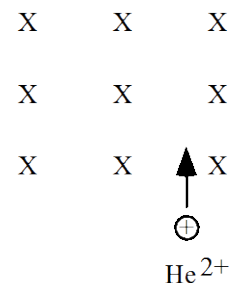

## Exercise Set 2: Charged Particles in Magnetic Fields

- Calculate the magnitude of the force when a charge of 1.00 C is injected into a uniform magnetic field of flux density  $1.00 \times 10^{-5}$  T if it moves at a)  $10.0 \text{ ms}^{-1}$  at right angles to the field; b)  $10.0 \text{ ms}^{-1}$  at  $45.0^\circ$  to the field; c)  $5.00 \text{ ms}^{-1}$  at  $30.0^\circ$  to the field.
- An electron is shot perpendicularly into a uniform magnetic field of flux density 10.0 T with a speed of  $1.0 \times 10^4 \text{ ms}^{-1}$ . What force does the electron experience?
- An alpha particle ( $q = 3.2 \times 10^{-19}$  C) experiences a force of  $1.00 \times 10^{-16}$  N when fired at an angle of  $30.0^\circ$  to a uniform magnetic field of flux density  $1.00 \times 10^{-2}$  T. With what speed was the alpha particle moving when it entered the field?
- In a cyclotron, protons experience a force of  $5.00 \times 10^{-15}$  N when fired into the device at right angles to the magnetic field. If the protons have a speed of  $1.00 \times 10^5 \text{ ms}^{-1}$ , what is the flux density of the magnetic field?
- A proton experiences a force of 1.00 N when fired at right angles into a uniform magnetic field. At what injection angle would it experience a force of 0.707 N?
- A proton enters a uniform magnetic field of flux density 2.00T with a speed 10.0% that of light. It initially moves at right angles to the field.
  - Find the magnitude of the force acting on the proton as it enters the field.
  - Calculate the radius of the circular path followed by the proton whilst in the magnetic field.
- Determine the diameter of the circular path followed by a charge of  $10.0 \mu\text{C}$  with mass  $1.00 \times 10^{-25}$  kg entering a uniform magnetic field of induction  $1.00 \times 10^{-2}$  T with a speed of  $1.00 \times 10^5 \text{ ms}^{-1}$  at: a) right angles to the field b)  $30.0^\circ$  to the field.
- An electron moving at velocity  $v$  experiences a force  $F$  up when it enters a uniform magnetic field of flux density  $B$  at right angles.
  - What force would be experienced if
    - the electron entered at  $30.0^\circ$
    - the electron entered at  $45^\circ$
    - the electron was injected at a speed of  $2v$
    - an alpha particle was injected instead of an electron?
  - Each particle follows a circular path after it enters the field. Determine the following ratios (for injection at  $90.0^\circ$ ):
    - $r_{\text{electron}} : r_{\text{proton}}$
    - $r_{\text{proton}} : r_{\text{alpha}}$
    - $d_{\text{alpha}} : d_{\text{electron}}$
- A proton is injected with a speed of  $1.00 \times 10^6 \text{ ms}^{-1}$  at an angle of  $37.0^\circ$  to a uniform magnetic field of 0.200T. Determine the
  - radius of the path of the proton
  - time taken to complete one revolution
  - pitch of the path of the proton.
- A beam of electrons is bent into a circle of radius 2.00 cm by a magnetic field of flux density  $1.00 \times 10^{-3}$  T. Calculate the speed of the electrons as a percentage of the speed of light.

## ANSWERS

- a)  $1.0 \times 10^{-4}$  N b)  $7.1 \times 10^{-5}$  N c)  $2.5 \times 10^{-5}$  N
- $1.6 \times 10^{-14}$  N at right angles to field
- $6.3 \times 10^4 \text{ ms}^{-1}$
- 0.31 T
- $45^\circ$
- a)  $9.6 \times 10^{-12}$  N b) 0.16 m
- a)  $1.0 \times 10^{-13}$  m b)  $5.0 \times 10^{-13}$  m
- a) i) 0.5 F up ii) 0.707 F up iii) F down iv) 2F up v) F down vi) 2F down  
b) i) 1:1800 ii) 1:2 iii) 3600:1
- a) 0.031 m b)  $3.3 \times 10^{-7}$  s c) 0.026 m
- 1.2%

# Particle Accelerators

Particle accelerators are used to accelerate charged particles to velocities and kinetic energies high enough to penetrate an atomic nucleus.

The high speed “bullets” usually protons or electrons are fired at nuclei of various atoms to break them apart.

By looking at the fragments from the impact, insights into the structure of the nucleus and various characteristics of the nuclear particles can be achieved.

Particle accelerators are classified as either linear or circular and include the following important examples:

- the Van de Graaff generator,
- Cathode ray tubes
- the Mass Spectrometer
- the Cyclotron, (used to accelerate positive ions)
- the Bevatron, (used to accelerate electrons).
- the Tevatron
- the Synchrotron
- Hadron Colliders

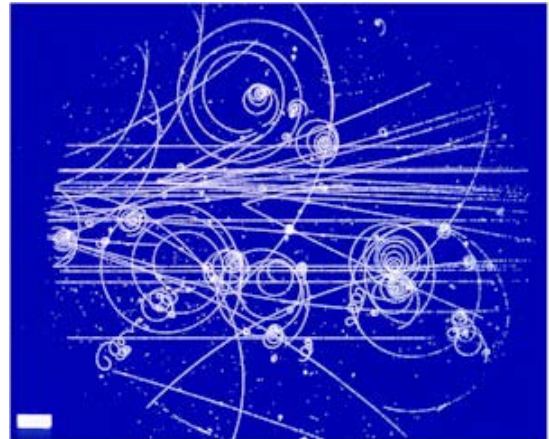

The first particle accelerator was derived from equipment designed to investigate the nature of electricity. The development of high voltage devices and vacuum technology (1850's) enabled research that ultimately led to the discovery of the electron and the identification of its properties.

The deflection of the electron in a magnetic field showed that it was negatively charged, and the radius of curvature provided the “charge to mass ratio” that helped to determine its mass.

As shown previously, a simple way to accelerate electrons is with an electric field using two parallel plates in an evacuated chamber.

When a charged particle is ‘fired’ into the space between the plates from the side, it will experience either a constant upward or downward force depending the plate polarity.

As with projectile motion, the particle will maintain its incoming ‘horizontal’ velocity; however, it will have constant acceleration at right angles to this horizontal velocity.

The combined effect results in a parabolic path while the particle is between the plates.

If you know the width of the plates, you can calculate the time for the particle to cross them in the horizontal direction, and so determine the amount of ‘vertical’ deflection.

This arrangement can be used inside a cathode ray oscilloscope (CRO) to deflect the beam either up and down, or left to right.

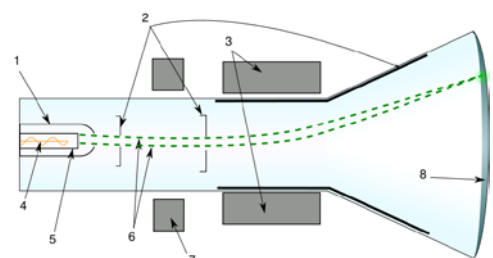
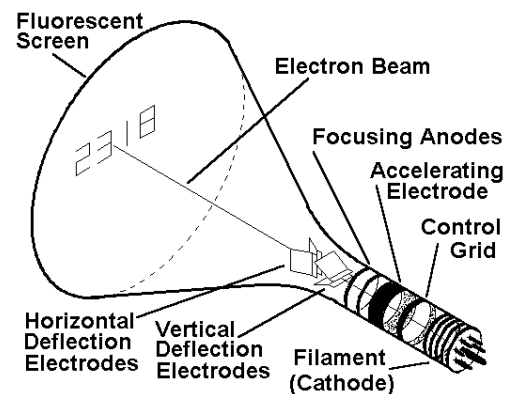

## The Electron Gun

An electron gun is a device to provide free electrons for a linear accelerator.

It usually consists of a hot wire filament with a current supplied by a low-voltage source.

When the current flows the filament glows red hot.

The electrons are, in a sense, 'boiling at the surface' of the filament.

The electric field can easily pull the electrons off the surface of the filament.

The hole in the positive plate is in direct line with the filament, and as the electrons are accelerated across they go straight through the hole to the target on the other side.

Electron guns produce the electrons that generate the picture in a television tube and it also the electrons for a synchrotron.

To attain higher speed seems to be a simple matter of obtaining a higher voltage. However, in the search for speed, Einstein's theory of relativity creates a problem, because as particles get faster, the energy in their mass — that is, their mass-energy — increases. This will be discussed in detail later.

Unfortunately, the cost of insulating such high voltages from the environment and the experimenters is expensive, and smarter solutions were needed.

The clever solution is to use the high but safe voltage to operate several sets of parallel plates in a line, so that after being accelerated by one pair, the electron then enters the next pair when it is accelerated again to a higher speed, and so on.

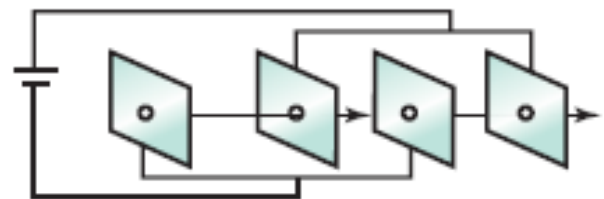

There is one problem with this design. As the electron leaves the positive plate, heading for the gap in the negative plate, it is going to be pulled back by the positive plate and repelled by the next negative plate. In fact, the electron will never get through that negative plate.

How can the design be improved? Perhaps, as the electron leaves the positive plate, the voltage of the plates is reversed. Now the electron will be pushed away from the plate it is leaving, which is now negative, and be attracted to the plate ahead, which is now positive.

This strategy has promise. Just switch the voltages on the plates backward and forwards as the electron goes through each gap. However, in accelerating the electron each time, the time to cross the gap will decrease. This problem though is simple to overcome: increase the size of the gap as the electron moves down the line. This will also enable the switching frequency to be kept constant.

Today, rather than using sets of parallel plates with increasing spacing, the linear accelerator uses tubes of increasing length, with the electrons fired down the middle of the tubes.

For a linear accelerator designed for high-speed electrons, the tubes are nearly equal in length because the electrons are approaching the speed of light.

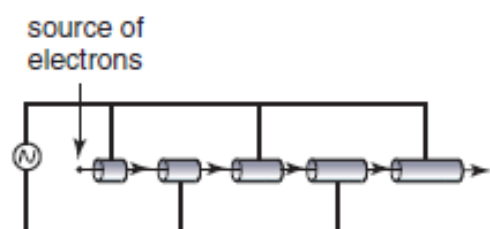



# The Mass Spectrometer

The forces exerted on moving charged particles by magnetic and electric fields make it possible to measure directly the masses of individual atoms.

The instrument for making such measurements is called a **mass spectrometer**.

Atoms of an element may be ionised by bombarding gaseous atoms with high speed electrons.

The bombardment ejects some of the electrons from the gas atoms that then become positive ions.

The ions are then accelerated and form a beam.

A beam of ions having a variety of velocities passes between a pair of crossed electric and magnetic fields of strength  $E$  and  $B$ .

For an ion to pass through slit  $S$  the force due to the electric field must be equal (but opposite in direction) to the force due to the magnetic field

$$\text{ie } F_e = F_m$$

$$Eq = Bvq$$

$$\text{Thus } v = \frac{E}{B}$$

Therefore the fields only allow ions with a velocity " $v$ ", equal to  $\frac{E}{B}$ , to pass through un-deflected and enter the right hand chamber through a slit  $S$ .

Ions with velocities greater or less than  $v$  are deflected and do not pass through the slit.

In the right hand chamber, the ions pass through another magnetic field at right angles to their path.

This field causes the ions to follow a circular path.

On completing half the circle, the ions strike a photographic plate which, when developed, shows a black line at  $P$ .

The distance  $SP$  is the diameter of the circle along which the ions have travelled.

The charge  $q$  on the ions must be a whole number of electronic units.

By substituting these values in the relationship  $mv = q r B$  the mass  $m$  of the ion is readily determined.

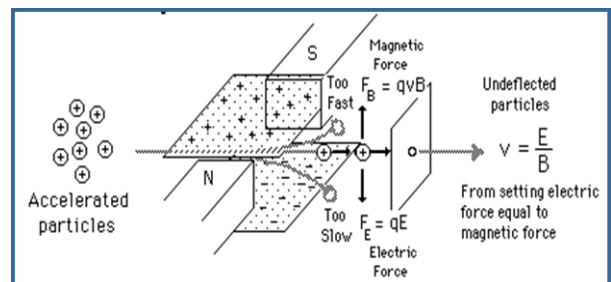
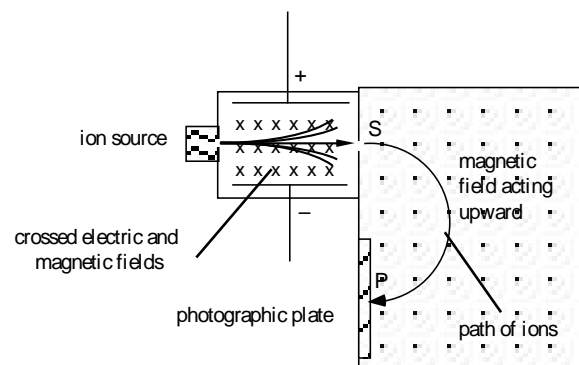
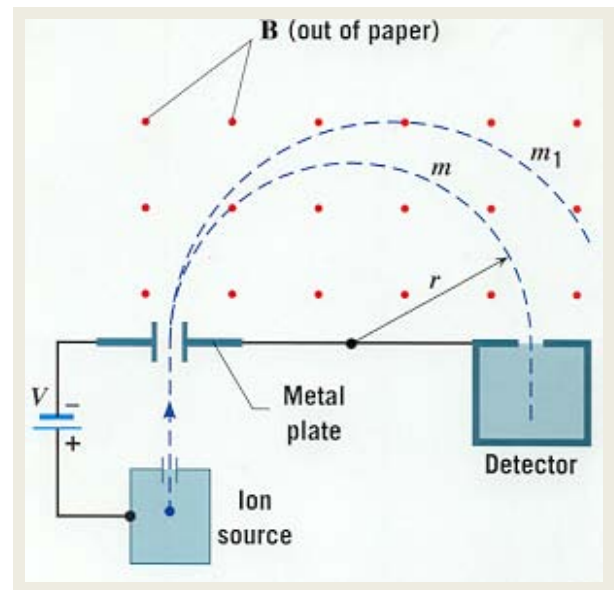

The measurement of the masses and the discovery, of the isotopes of the atoms of all the elements has been made possible by the mass spectrometer.

The instrument may also be used to separate isotopes.

Replacing the photographic plate with containers at specific positions, different isotopes may be collected.

Pure samples of isotopes are thereby made available.

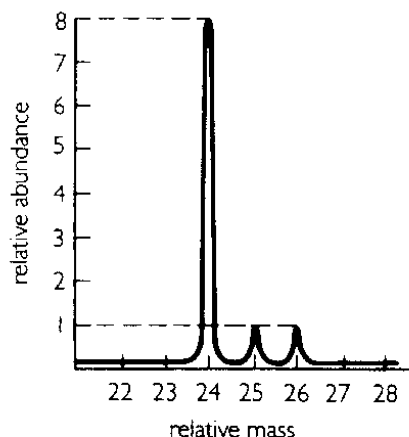

### Exercise Set 3: The Mass Spectrometer

1. The diagram represents a simplified mass spectrometer. Ions drift through the aperture, accelerated by a high voltage.

- What is the polarity of the ions shown?
- What is the accelerating potential required for a velocity of  $3.00 \times 10^6 \text{ ms}^{-1}$ ?

A proton is observed to have a path radius of 0.50 m.

- Given the same operational settings, determine the radius of the path for an alpha particle.

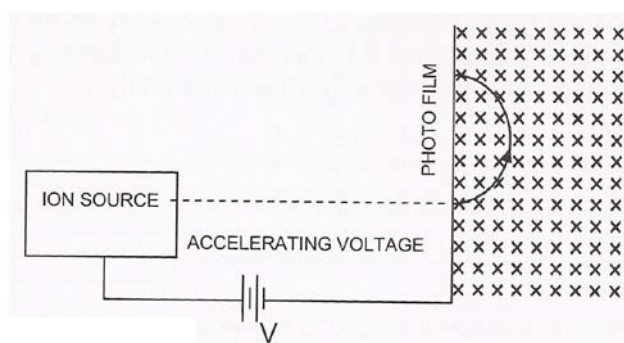

2. Chlorine consists of two isotopes,  $^{35}\text{Cl}_{17}$  and  $^{37}\text{Cl}_{17}$ . Assume that protons and neutrons have masses of  $1.66 \times 10^{-27} \text{ kg}$  and when ionised, chlorine gains an extra electron (charge  $1.6 \times 10^{-19} \text{ C}$ ). A mass spectrometer is used to analyse the relative abundance of each isotope so the ions from the chlorine source are accelerated across a potential of 154 V and enter a uniform magnetic field of strength 0.24 T.

- Determine the work done on the ions as they are accelerated.
- Determine the velocity of the ions as they enter the magnetic field.
- Determine the radius of each ion's path.

3. The diagram represents a simplified mass spectrometer. The magnetic field is set to 2.45 T.

- Determine the minimum distance that the photographic plate can be from the slit in order to record the path of an alpha particle entering the magnetic field with a velocity of  $3.90 \times 10^6 \text{ ms}^{-1}$ .
- Determine the Accelerating Potential that will be required to "fire" the particles into the magnetic field chamber at this speed.

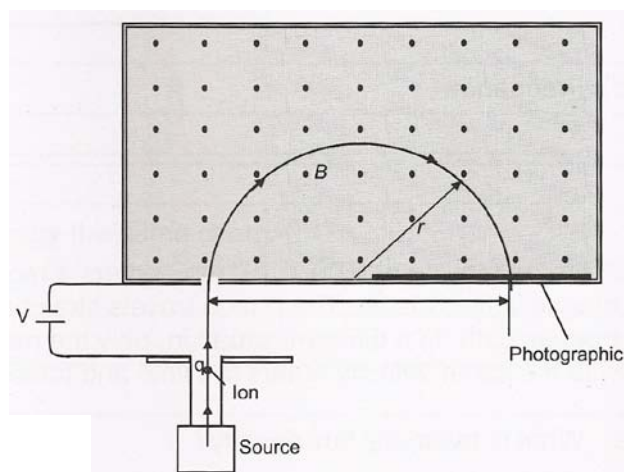

### ANSWERS

- 1.
- 2.
- 3.

# The Cyclotron

A cyclotron is used to produce high energy (very high velocity) charged heavy hydrogen ions (deuterons).

A cyclotron consists of two dees (D shaped metal cylinders).

The dees are enclosed in a vacuum chamber situated between the poles of a powerful electromagnet.

A high frequency alternating potential difference around  $2 \times 10^5$  volts is applied between the dees.

Positively charged deuterons formed in the gap between the dees are accelerated by the potential difference across the gap.

On entering a dee, the strong magnetic field produced by the electromagnet exerts a force on the moving particles causing them to follow a circular path.

By the time the deuterons return to the gap between the dees the pd across the gap has reversed and the deuterons are again accelerated across the gap to the opposite dee.

This process is repeated many times, with the deuterons following a slowly expanding circular path.

On each occasion the deuteron gains energy equivalent to about  $2 \times 10^5$  eV. Typically a deuteron may pass between the dees 25 to 50 times thus gaining energy up to 10 MeV.

Finally the deuterons are attracted out the dees by a negatively charged deflecting plate and are directed upon the target element whose nucleus is to be bombarded.

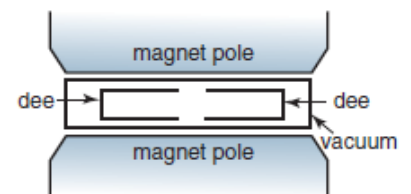
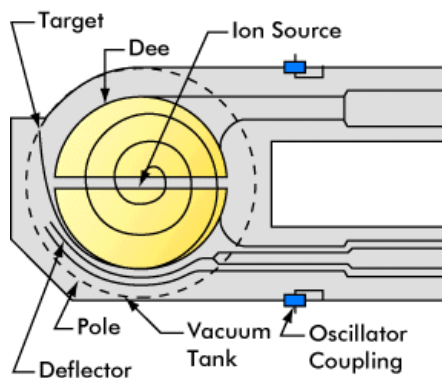
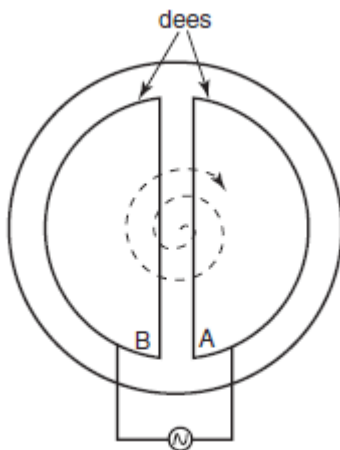
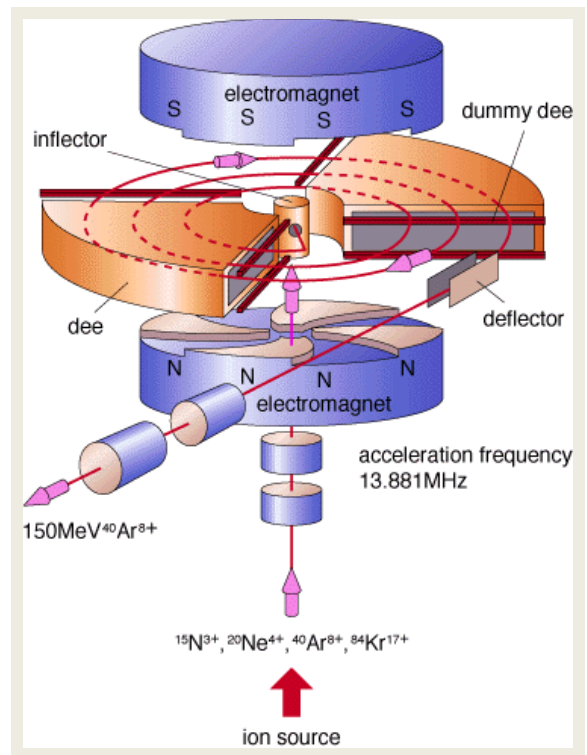
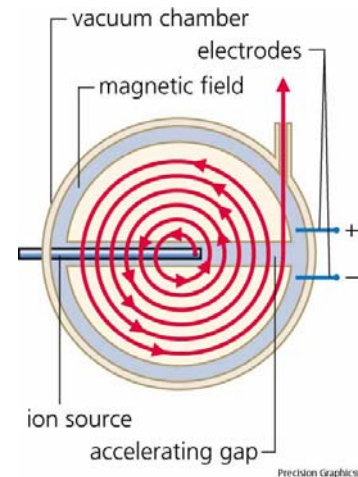

## Early Synchrotrons -The Bevatron and the Tevatron

The cyclotron was an early design for a particle accelerator that was replaced when speeds close to the speed of light were desired.

The strategy used in the synchrotron to overcome the relativistic effect is to progressively increase the magnetic field as the particle gains speed, keeping it in a path of constant radius.

The economics of building of a synchrotron is governed by The relationship

$$r = \frac{mv}{Bq}$$

The scientists want a machine to achieve a desired energy or speed for a particle.

The larger the magnetic field, the smaller the radius of the path.

However, the major operating cost of a synchrotron is the achieving and maintaining of the magnetic field strength that is done with high-current electromagnets.

The speed of the particle is given by  $v = \frac{rBq}{m}$

Therefore, for a given particle the speed depends on the product of the radius and the magnetic field strength.

To minimise operating costs, the radius needs to be large.

In fact, the radius can be as large as 1 km.

A giant magnet with a 1 km radius is not available.

Rather, small magnets are placed on the circumference of the synchrotron (the ring), where the particles are.

Between these magnets are high voltage accelerators to top up the energy requested by the experimenter.

It would be wasteful to inject particles into a synchrotron at low speeds and let the ring of magnets force them up to almost the speed of light.

Instead a linear accelerator outside the ring is used to accelerate the particles up to a significant fraction of the speed of light before they are directed into the ring along a tangential line.

In 1943 Australian physicist Marcus Oliphant, suggested modifying the design of the cyclotron to produce the synchrotron.

In 1946, his team began construction of a proton synchrotron.

An American team, who started on their synchrotron after the UK team, were the first to be operational, producing 900 MeV protons in May 1952.

The UK team were operational in July 1953, and went on to produce 2900 MeV in January 1954.

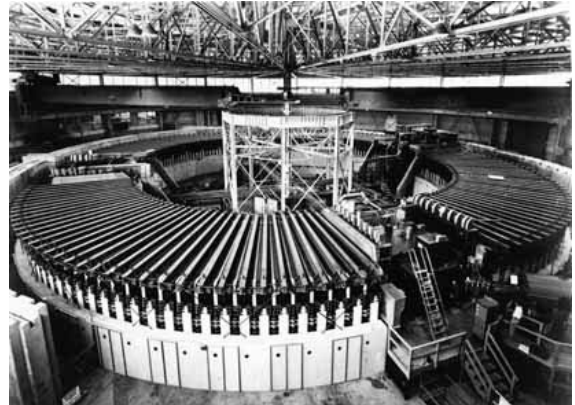

The Bevatron



The Tevatron (Fermi lab)



Later in 1954, a second American synchrotron (Bevatron), rated at 6000 MeV, was built at Berkeley, California; and in 1955 a Russian 10 000 MeV machine was built.

By 1960 an internationally owned machine of 30 000 MeV was built in Geneva.

Some idea of the speed attained by particles in modern accelerators may be gained from available data obtained on the Berkeley Bevatron.

The prefix beva refers to billion electron volts.

This accelerator is designed to furnish protons with energies of 6 billion electron volts.

In this device, each proton takes about 2 seconds to acquire a final speed close to the velocity of light.

During this time, it makes several million revolutions inside the Bevatron and travels about 500,000 km.



## The Large Hadron Collider

The Large Hadron Collider (LHC) is the world's largest and highest-energy particle accelerator, a synchrotron intended to collide opposing particle beams of either protons at an energy of 7 trillion eV per particle, or lead nuclei at an energy of 574 TeV per nucleus.



The term Hadron refers to particles composed of quarks.

It is expected that it will address the most fundamental questions of physics, advancing our understanding of universal laws.

The LHC lies in a tunnel 27 kilometres in circumference, as much as 175 metres beneath the Franco-Swiss border near Geneva, Switzerland.

The LHC was built by CERN, the European Organization for Nuclear Research, with the intention of testing various predictions of high-energy physics, including the existence of the hypothesized Higgs boson and of the large family of new particles predicted by super-symmetry.

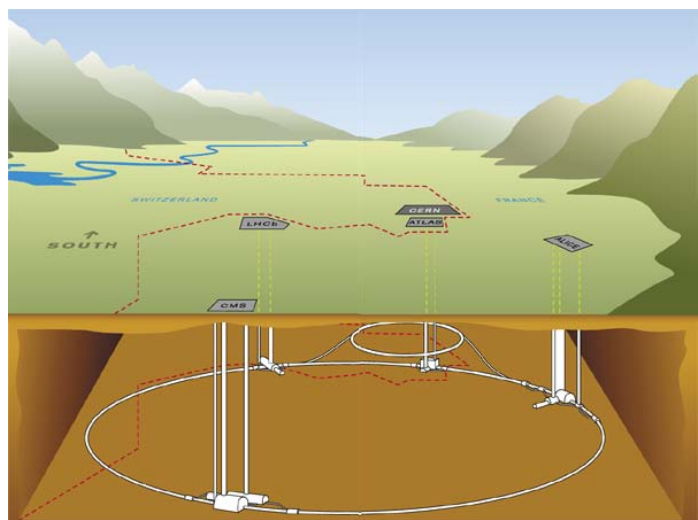

It is funded by and built in collaboration with over 10,000 scientists and engineers from over 100 countries as well as hundreds of universities and laboratories.

With a budget of 9 billion US dollars (Jan 2010), the LHC is one of the most expensive scientific instruments ever built.

Physicists hope that the LHC will help answer many of the most fundamental questions in physics:

concerning the basic laws governing the interaction and forces among the elementary objects,

the deep structure of space and time,

regarding the intersection of quantum mechanics and general relativity, where current theories and knowledge are unclear or break down altogether.

The collider tunnel contains two adjacent parallel beam pipes that intersect at four points,

each containing a proton beam, which travel in opposite directions around the ring.

1,232 dipole magnets keep the beams on their circular path, while an additional 392 quadrupole magnets are used to keep the beams focused, in order to maximize the chances of interaction between the particles in the four intersection points, where the two beams will cross.

In total, over 1,600 superconducting magnets are installed, with most weighing over 27 tonnes.

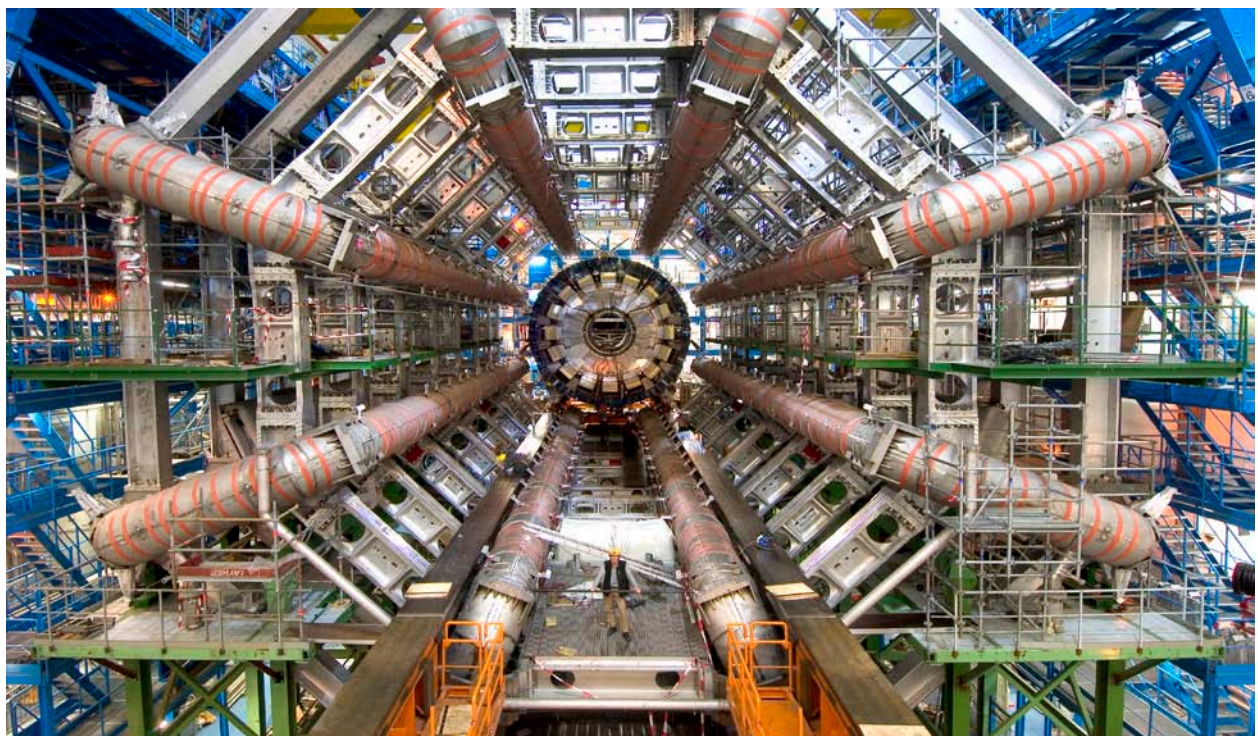
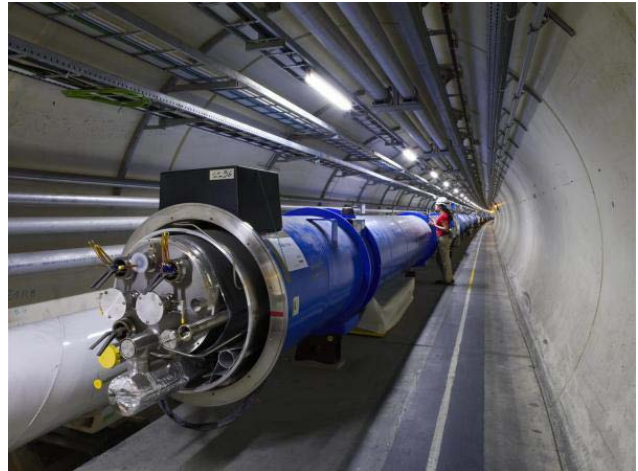

Approx. 96 tonnes of liquid helium is needed to keep the magnets at their operating temperature of 1.9 K ( $-271.25\text{ }^{\circ}\text{C}$ ), making the LHC the largest cryogenic facility at liquid helium temperature.

# The Australian Synchrotron

The Australian Synchrotron is a 3 GeV synchrotron radiation facility built in Melbourne, Victoria. The Synchrotron building is located in Clayton near the Monash University Clayton Campus.

Officially opened in July 2007, the Australian Synchrotron is one of fewer than 40 similar facilities around the world. It is the largest stand-alone piece of scientific infrastructure in the southern hemisphere.

The Australian Synchrotron is a light source facility (in contrast to a collider).

It uses particle accelerators to produce a beam of high energy electrons which are placed within a storage ring that circulates the electrons to create synchrotron light.

The light is directed down separate beam-lines at the end of which may be placed a variety of experimental equipment contained within the end-stations.

Modern synchrotrons are designed to produce a very intense, very narrow beam of electromagnetic radiation with frequencies ranging from infra-red to high-frequency X-rays.

The properties of the radiation make the synchrotron such a powerful investigative tool.

The extensive range of the frequencies of the radiation enables it to be used for a diverse and seemingly contradictory set of activities.

For example, a synchrotron could be used to:

- determine the location of individual atoms in a haemoglobin molecule
- show precise images of blockages in small arteries in the heart
- make very small microscopic machines that could travel in arteries to check for blockages
- investigate the different steps in a chemical reaction that is over in a fraction of a second
- examine how a catalyst increases the rate of reaction.

The Australian synchrotron is illustrated below:

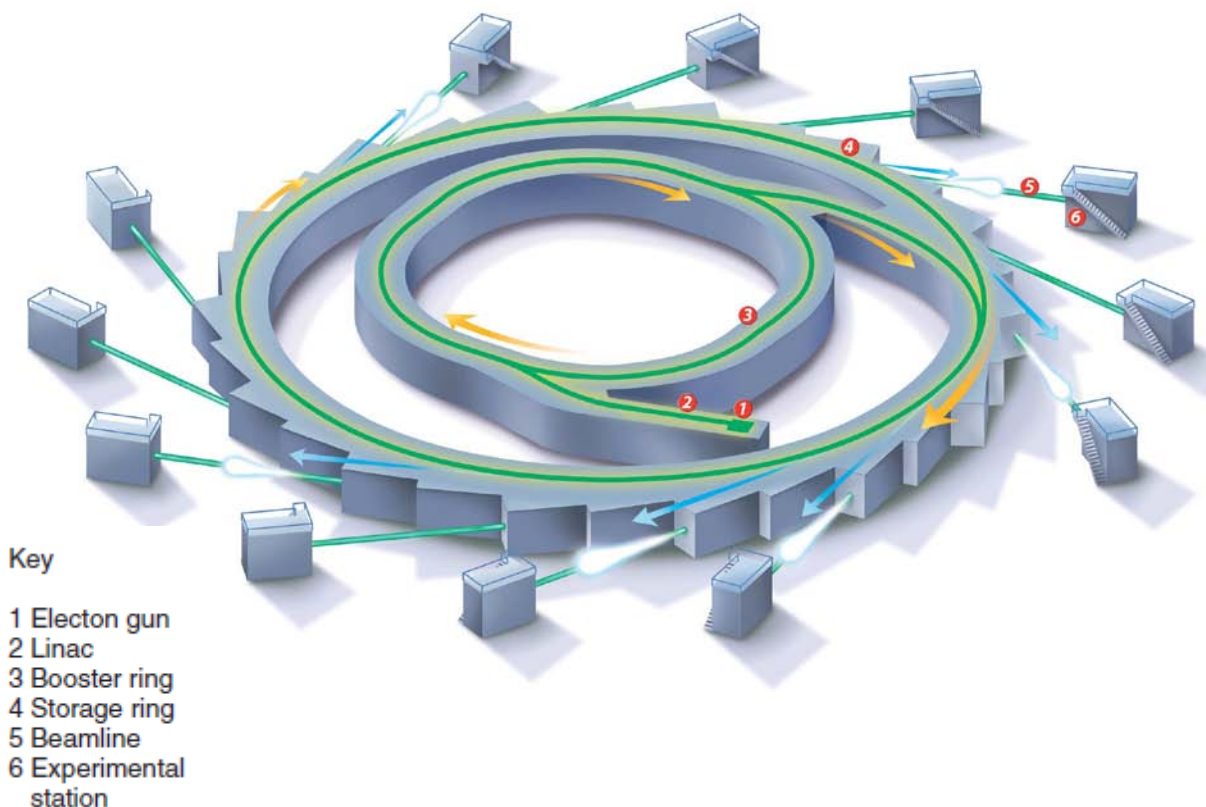

## Electron gun

A thin tungsten wire, or a filament, is heated by a current to about 1000°C.

This is the type of source used in television sets.

Electrons are attracted out of this wire by a voltage of 120 kV.

Electrons achieve a speed of  $1.78 \times 10^8 \text{ m s}^{-1}$ , which is 59% of the speed of light.

At this speed the mass of the electron has shown a relativistic increase of 25%.

## Linear accelerator (linac)

The series of accelerating chambers accelerate the electrons up to  $2.998 \times 10^8 \text{ m s}^{-1}$ , which is 99.995% of the speed of light. This is achieved by an overall voltage of 100 million volts.

## Circular booster (booster ring)

Accelerating chambers in the booster ring increase the energy by 30 times;

however, because of the effect of relativity, the speed of the electron increases only marginally, while its mass increases substantially.

The electrons are now even closer to the speed of light, at  $2.997\ 92 \times 10^8 \text{ m s}^{-1}$ , which is 99.999 994% of the speed of light, with energy of 3 GeV.

The booster ring is the part of a synchrotron that takes the already fast electrons from the linear accelerator and increases their speed and energy before injecting them into the storage ring.

## Storage ring

The storage ring is 216 m in circumference, with a radius of 34.3 m.

The ring, however, is not really circular. It actually consists of 13 short straight-line sections, each about 4.6 m long connected by circular arcs.

The electrons are deflected into a circular path by the magnetic field, and synchrotron radiation is emitted here along the tangent to the path.

In the straight-line sections, the electrons are accelerated back up to speed to compensate for the loss of energy due to the emission of the radiation.

The storage ring of a synchrotron is where the electrons, now at maximum possible speed, produce radiation for use in the beam-lines.

Magnets in the circular arcs curve the electrons around. The bending is done by a vertical magnetic field with the north pole above the beam. This magnetic field is called a dipole field, because there is one north pole and one south pole.

In the storage ring, there is also a quadrupole magnetic field, which is created in the space between two coils with their currents travelling in opposite directions.

This shape field can also be made with two north and two south poles, hence the name 'quadrupole'.

This magnetic field focuses the beam.

There is also a sextupole magnetic field, with three north and three south poles, which brings the slightly slower and faster electrons back to the pack.

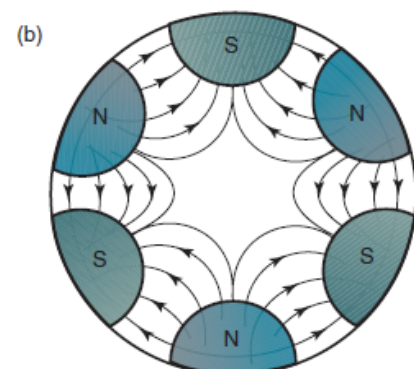



Synchrotron radiation is emitted in circular arcs. Radiation is emitted in a fan shape where magnets bend the electron path.

Other parts of the storage ring have **undulators** and **wigglers**, which consist of closely varying magnetic fields.

In the undulators, the fields are designed to produce narrow bright beams; whereas in the wigglers, a wide powerful beam is produced.

An undulator is a row of magnets with alternating polarity that produce brighter synchrotron radiation of a specific frequency. Undulators are located in the storage ring.

A wiggler is a row of magnets with alternating polarity that produce brighter synchrotron radiation of shorter wavelengths. Wigglers are located in the storage ring.

### Beam-lines

Synchrotron radiation is directed into separate experimental stations. Each beam line is usually set up for a particular application using a specific frequency range.

A beam-line is the line along which the synchrotron radiation passes to reach the target.

The frequency for the beam-line is selected by a mono-chromator, which means that only one frequency leaves the end of the beam-line and hits the target.

A mono-chromator is a device that allows radiation of only one frequency through.

### Experimental stations

The synchrotron is expected to have up to 20 end stations, where separate experiments using specific wavelengths can be conducted simultaneously.

Research and summarise some of the processes for which beam-lines are used in the table provided:

PROCESS	SCIENCE or INDUSTRY APPLICATIONS	EXAMPLE	PHOTON ENERGIES

